

K L I M B O

RAISING YOUR CHILDREN PROPERLY



The self-retracting step Klimbo responds to the little ones' need for independence by giving them easy access to lavatories in public restrooms.

Klimbo demonstrates a concern for young families, promotes hand hygiene and, consequently, public health.

Klimbo represents a clear advantage, both budgetary and organizational, compared to lowered sinks by ensuring an optimal use of the premises by all users.

PLACES WHERE KLIMBO IS IN DEMAND

Institutional buildings (libraries, multifunctional centers, schools, daycares, sports and recreational facilities, museums, citizens' services, stadiums) • Shopping centers • Theaters • Rest areas and service centers • Hospitals and clinics • Hotels • Fun and water parks, zoos • Restaurants • Airports, train and bus stations



ELEGANT

Fruit of a long collaboration between designers, architects and engineers • Projects an image of round contours that is both contemporary and playful • Available in the 190 **RAL classic** colors and in a **multitude of metallic finishes by Axalta Coating Systems**



ROBUST AND SAFE

Free from pinch points and sharp edges • Imbedded adhesive tread • Load capacity of 815 lb (370 kg) • Anti-theft and vandal-resistant

EASY TO MAINTAIN

Rustproof • Encapsulated base mops won't get caught in • Resistance to cleaning products

TECHNICAL SPECIFICATIONS

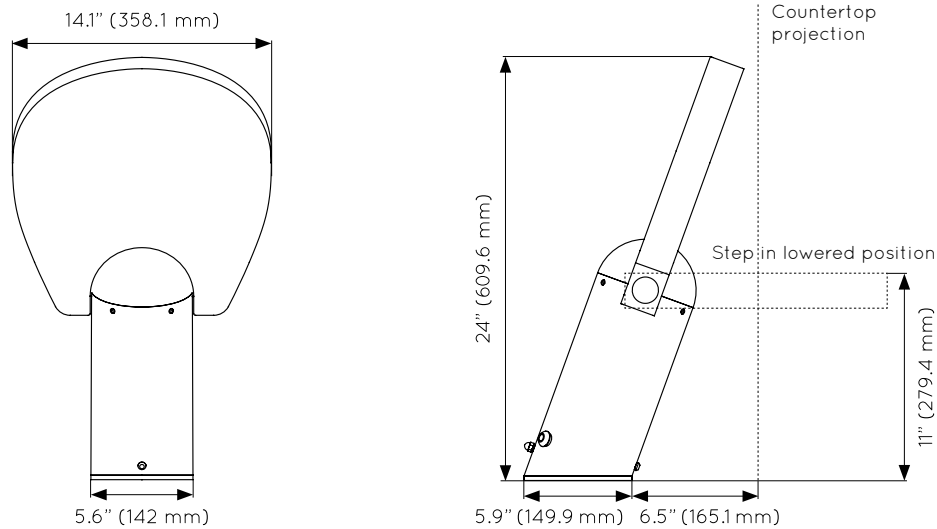

Materials

Exterior components	Chassis made of aluminium T6061 finished with Axalta polyester thermosetting powder coating • By special order, all Axalta powder coatings can be applied • Imbedded adhesive tread, made from recycled tires
Interior components	Steel and aluminum coated with white lithium grease containing PTFE
Load-bearing parts	Tempered steel
Anchors	Requires two masonry anchors • Fast and easy installation in floor concrete slab • Three carbon steel masonry anchors are provided: two 3 3/4" and one 2 3/4" • Refer to the installation guide for details
Hardware	Blackened 18-8 stainless steel • By special order, available in 316 stainless steel for chlorine-heavy environments like pool changing rooms
Stickers	Logo under the step (transparent PVC) • Signaletic on the step edge (transparent PVC) • Three signaletic panels to stick at eye level are provided in three colors: white, black (PVC) and brushed metal (polyester)

Additional information

Load bearing capacity	815 lb (370 kg)
Warranty	Five years against manufacturing defects and against failure of the retraction mechanism
Customization	By special order, Klimbo can be adapted to the customer's brand and serve as a medium to communicate with its clientele
CAD et Revit files	Available on the web site: www.klimbo.co/en-specification
Patent	Patent pending in all territories

Logistical data

Unit weight	20 lb (9 kg)
Packaged unit	22 lb (10 kg)
Expedition box dimensions	26" x 15" x 8" (71 cm x 38 cm x 20 cm)

KLIMBO IS MANUFACTURED BY

DLR inc.
 P.O. Box 39026, Station Saint-Alexandre
 Montreal (Qc) H3B 0B2 | Canada
www.klimbo.co | www.facebook.com/KlimboStep
 questions@klimbo.co

*Published on November 12th 2017
 Content subject to change without notice*

REPRESENTATIVE / DISTRIBUTOR

